

.....

.....

:

.....	- -
.....	- -
.....	- -
.....	- -
.....	- -
.....	- -

:

.....	- -
.....	- -

..... **A**

..... **B** - -

..... **C** - -

..... **D** - -

..... **E** - -

..... - -

..... - -

.....

:

:

..

:

1- Time
2- Cost
3- Performance

»

«

A,B,C,D,E

<i>PET2</i>	A
<i>PTA2</i>	B
	C
	D
	E

--

<<

>>

:

-
-
-
-
-
-

--

()

:()

	C	EP		
				A
				B
				C
				D
				E

--

()

:

() :()

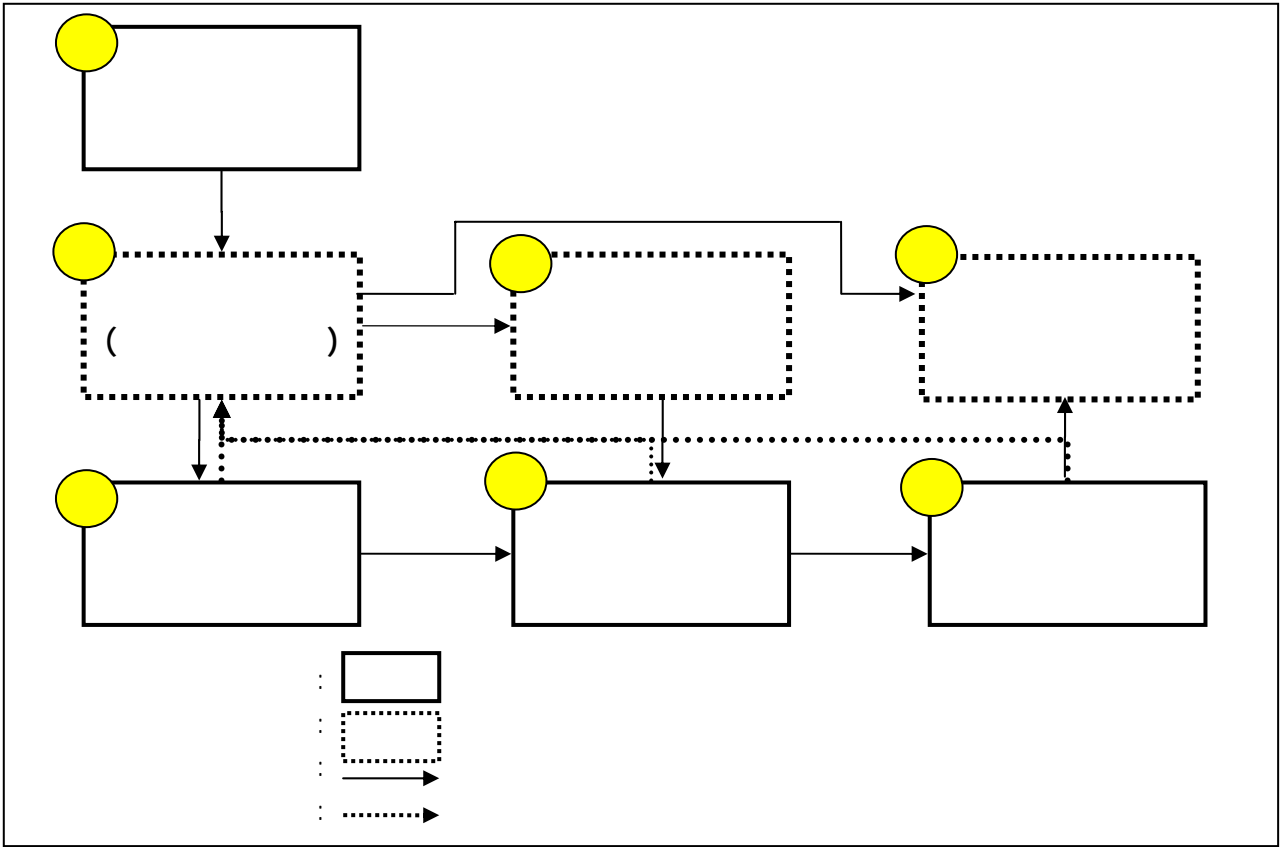

--

()

:

:()

	<ul style="list-style-type: none">•••	
:	<ul style="list-style-type: none">•➤➤➤➤•➤➤➤	
	<ul style="list-style-type: none">• <p>()</p>	
()	<ul style="list-style-type: none">••••	
	<ul style="list-style-type: none">•	

..

:

()

C EP



C

EP

(C /EP /)

C EP ()

--

:

•

★

★

:



✦

:

●

✦

✦

:

●

✦

✦

:

●

✦

✦

✦

()

●

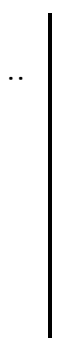

:

.

.

..

:

A

A

A

()

()

A

(:)

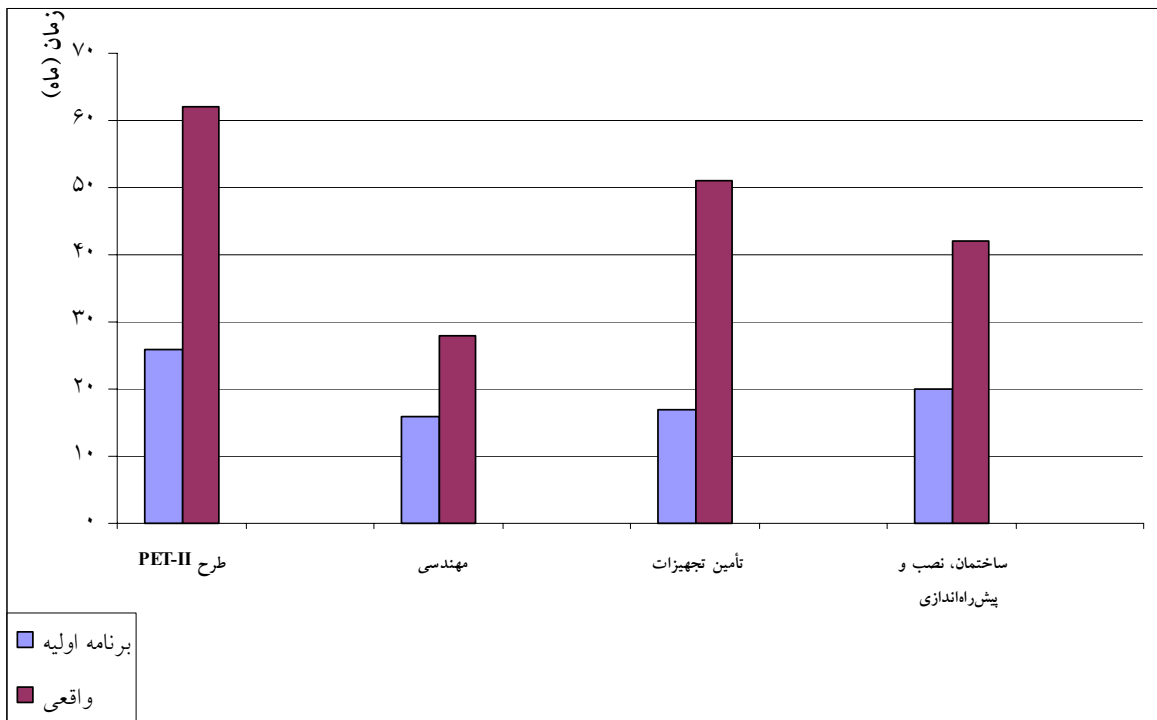

	A			
()	1	I	I	1İ
()	1	1	I	Ö1
()	Ö	I1	ÖÖ	11
/ / :	ÿ	Iİİÿ	1ÿ	ÿ

(WBS)

A

()

- :

-

()

.

..

|

:

()

A

A

:()

					WBS
ú	ú ōúI Iú1 ĭ	ě ĭÿ	úř ú1 ú1	Iĭ ú uřĭ uřř	
Iřĭ	Iřuř ĭú ĭĭú 1	řěIĭÿ	I1uř ú 1ĭú 1	I úI 1uř 1ú	
	ú I ú11 ú 11	ěřĭÿ	úř ú ú 1	ú ĭú ř1ú1I	
řř	řú uřĭ ú řI	ĭěĭĭÿ	1uĭ uř ú1 ř	ú řĭú Iřuř I	
1řĭ	řú11 ú IIuĭ1ř	ěIĭÿ	Iú1 ú ĭřú ř	ú1 řú I ú	

..

:

A

A

)

.(

A

..

:

..

:

..

:

..

:

..

:

..

:

..

:

..

:

..

:

B - -

B

B ()

()

B : ()

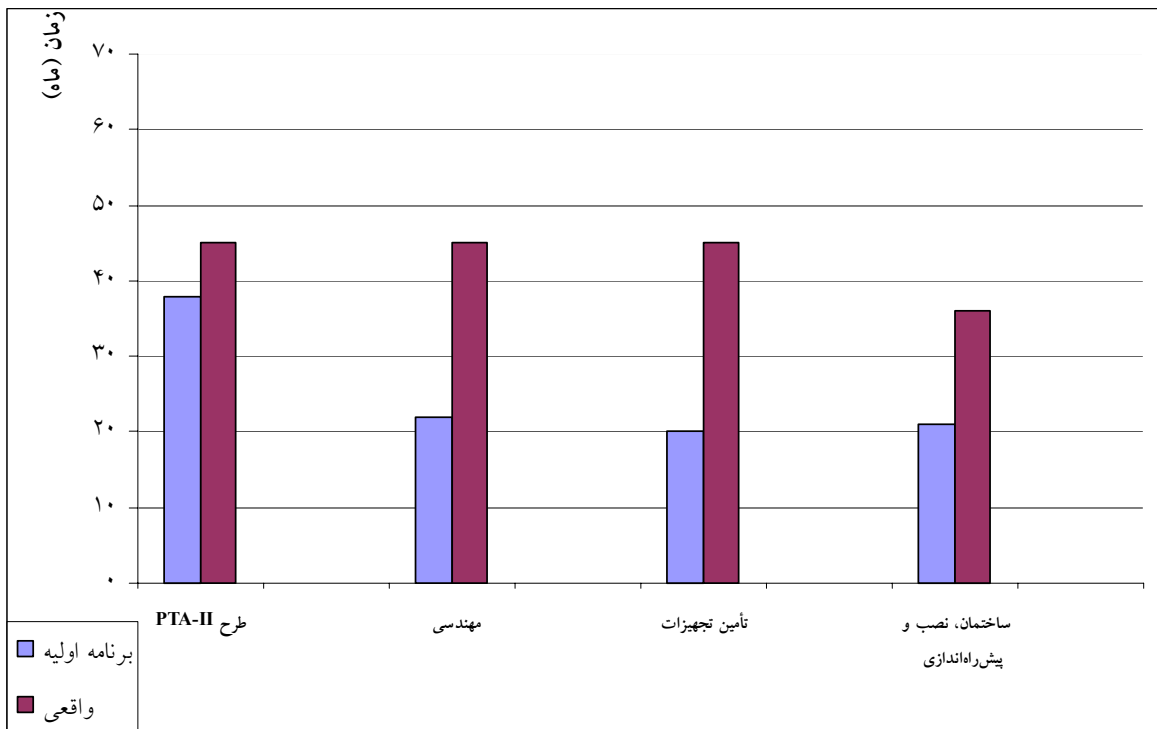

	B			
()	Ö	ll	lİ	lI
()	ö	ö	ö	Ö
()		lÖ	l	I
/ / :	ÿ	Iİİÿ	Iİİÿ	öÿ

B

B ()

- :

-

()

B :()

		WBS	WBS
	ouŮo uŮ Ůuŕŕŕ		Iě1ěI
	Ů Iu' 1uŕŕŕěŕŕ		Iě1ě1
	I ŕuŕŕŕuŕŕŕěŕŕ		Iě1ěŮ
	IŮu' I ŕŕŕŕuŕŕŕěŕŕ		IěŮěI
	Iu'1 Iuŕŕŕŕuŕŕŕěŕŕ		IěŮě1
	II ŕ ŕ1u' Iu' ěŕŕ		IěŮě1
	ŮŕuŮ ŕ Ů ŕ ěŕŕ		IěŮě1ě1
	uŮ uŮ Ůu' ěŕŕ		IěŮě1ě
	Iŕu' I1uŕŕ1 ŕIŮŕŕŕŕ		IěŮě1ě
	1IŮu' ŕIu' Ůěŕŕ		IěŮě1ě

B ()

B :()

					WBS
ŕ ŕ Ů	Iŕ uŮ1 uŮ ŕI I	Ůě ŕŕ	I11uŕŕ 1u' ŕ ŕŕ	II ŕ ŕ1u' Iu'	
ŕu' ŮŮ	ŮŕuŮ ŮuŮ1ŕuŮ	ě ŕŕ	Ů ŕ ŕ Ů uŮIŮ	ŮŕuŮ ŕ Ů ŕ	
ŕ 1	ŕ Ů ŕ Iu' IŮ	IěŮŕŕ	ŕŕ ŕ ŕ 1	uŮ uŮ Ůu'	
1u' Ů	ŕ ŕ I ŕ Ů	ŮěIŕŕ	Ůu'1 ŕ Ů ŕŕŕŮ	Iŕu' I1uŕŕ1 ŕIŮŕ	
uŮ1Ů	IŮ1u' ŕ11	1ě1ŕŕ	ŕI ŕ I	1IŮu' ŕIu' Ů	



B

B

.()

B



..

:

..

:

..

:

..

:

..

:

..

:

..

:

..

:

C - -

C

() C

()

C : ()

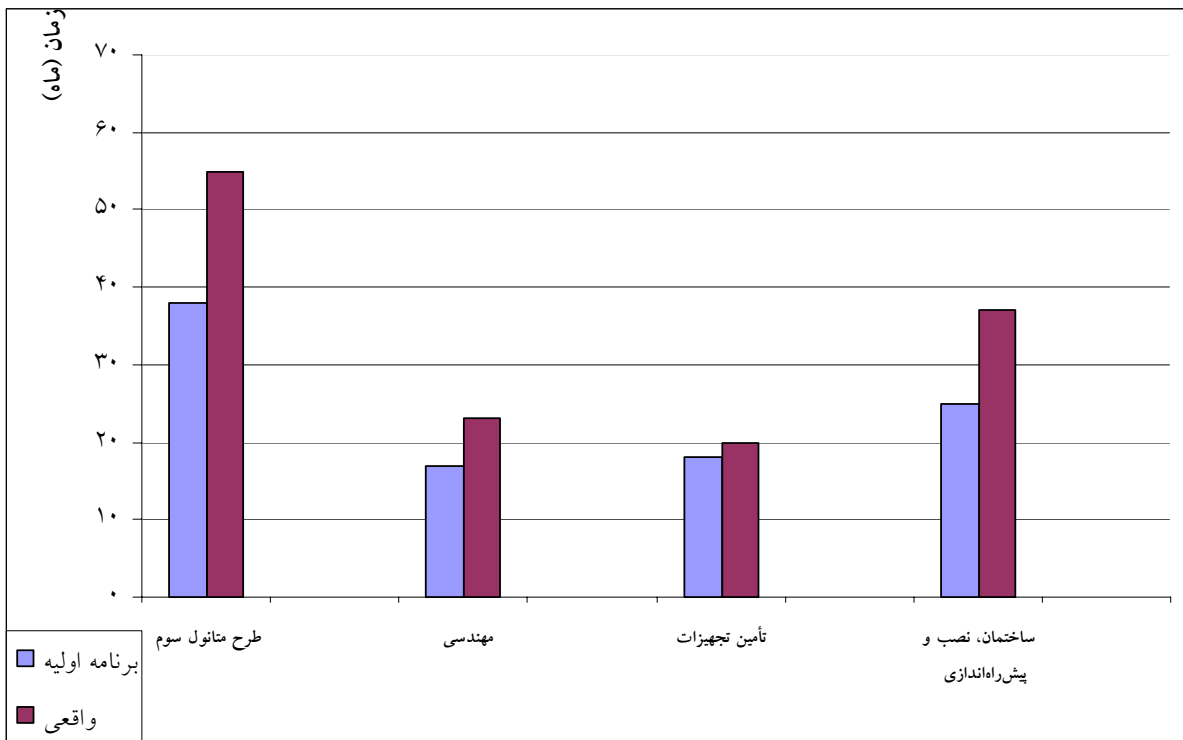

	C			
()	Ö	I	I	1
()		1Ö	1İ	Ö
()	I		1	I1
/ / :	Iİİİÿ	Iİİİÿ	Iİİİÿ	Iİİİÿ

C

C

C

C

)

(

C

..

:

..

:

..

:

..

:

..

:

..

:

..

:

..

:

D - -

/ D

()

()

D : ()

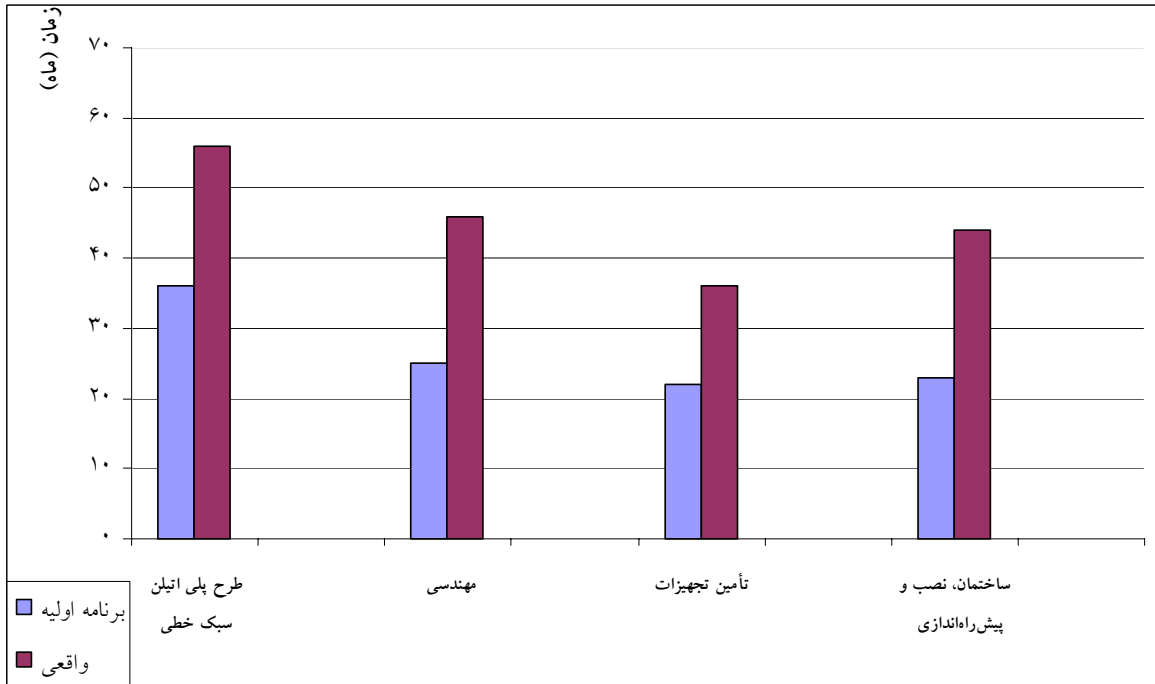

	D			
()	Ö	1	11	1Ö
()		Ö	Ö	ÖÖ
()	1İ	1I	IÖ	1I
/ / :	Iİİÿ	Iİİÿ	Iİİÿ	Iİİÿ



D ()



D

:()

()	()	WBS	
1			
I			
1ĭ	I		
I	1ĭ		
I	11		
I	11		
I1	IÖ		
	1I		
ö	11		
IÖ	1Ö		
II	1		
I	Iĭ		
II	IÖ		
II	IÖ		
II	IÖ		
II	IÖ		
II			

WBS

D

()

D

)

.(

..

:

..

:

..

:

..

:

..

:

..

:

..

:

..

:

E - -

E

()

() E

()

E : ()

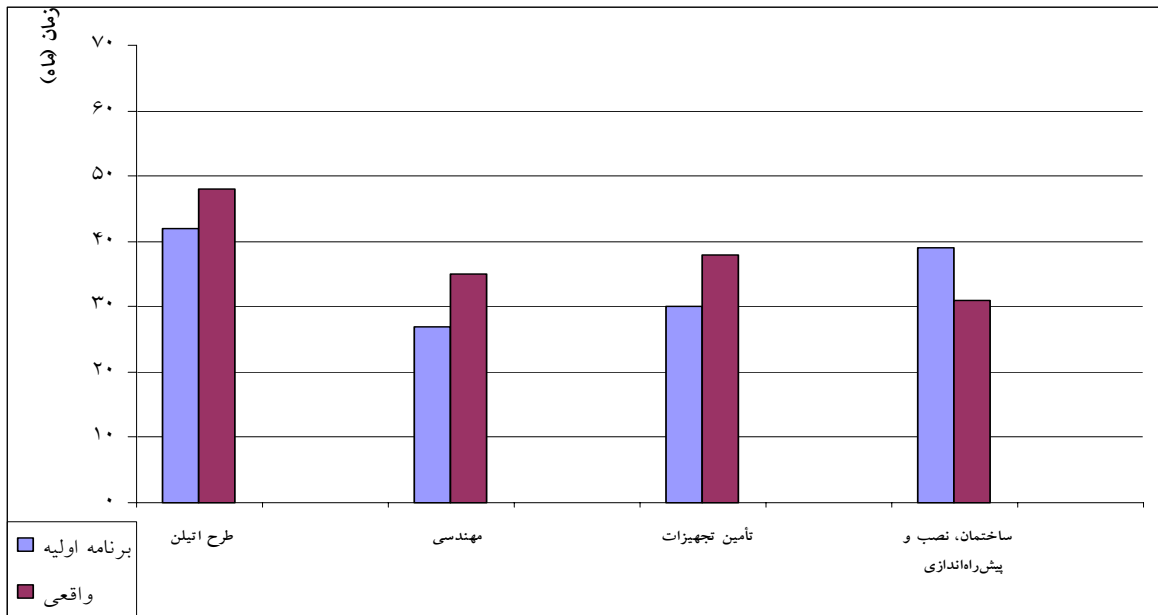

	E			
()	ō1	1	ōĩ	ō
()	ō	ō	ō	ōI
()				
/ / :	ōÿ	Iĩĩÿ	ÿ	ĩÿ

E

()

E

..

:

E : ()

()	()	WBS	
	1		
	1ĭ		
	1Ö		
	11		
	I		
Ö	1		
IÖ	1		
II	1		
IÖ	I1		
	1		
IÖ	II		
Iĭ	Ö		
	1		

WBS E ()

E : ()

		WBS	WBS
	IÖuT 1u1öiëiï		Ië1ë1
	ú iuïiïëiï		Ië1ëÖ
	1öÖu ÖIu iïëiï		IëÖëI
	öÖu' u' IIëiï		IëÖë1
	IÖ uTi uïiïuïiïëiï		IëöëI
	1u' ö uöÖiuÖiïëiï		IëöëIëI
	u' ÖuÖ iuïiïëiï		IëöëIë1I
	uïiïuïiïëiï	HVAC	IëöëIë1I
	ö1u1 iuïiïëiï		IëöëIë11
	u' 1u' iuïiïëiï		IëöëIë1Ö
	u' 1uïiïuïiïëiï		IëöëIë1ö
	i uïiïuïiïuïiïëiï		Iëöë1
	1 Iu' öu11iuöiïëiï		Iëöë1ëI
	ö1uöiïu' u1iïëiï		Iëöë1ëÖ
	1IuÖÖÖu' Ö uïiïëiï		Iëöë1ë
	Ö uÖIiuö Iuöiïëiï		Iëöë1ë

E ()

E : ()

					WBS
u'	IÖ uTi uïiïuïiï	IïiëiïY	ÖIöuÖ1IuT u'	IÖ uTi uïiïuïiï	
Iuö ö	1öÖu' I uïiïuïiï	ö ëÖiY	I 1u' uï u' I	i uïiïuïiïuïiï	
Öu1 ö	1öuT Iu' ö uT	ë iY	u11 uIÖ uöÖ1	1 Iu' öu11iuöiï	
u' i	Iuö öu'iÖIuöi1	Öë iY	Ööu' u' 1 u1 1	ö1uöiïu' u1iï	
u'	1 uïiïuö	Ië1iY	Öu' Ööu' uö	1IuÖÖÖu' Ö uïiï	
Iuö	öu' 1iu' Ö	ië1iY	Iu'iÖIu' 1uö	Ö uÖIiuö Iuöiï	

| | | | |

.

.

E

.

.

)

.(

.

.

E

.

..

:

..

:

..

:

..

:

..

:

..

:

..

:

..

:

..

:

- -

.

.

.

.

.

.

..

:

..

:

..

:

..

:

..

:

..

:

..

:

..

:

..

:

..

:

..

:

..

:

..

:

..

:

..

:

- -



APOL01

APOL02

APOL03

()

APOL04

APOL05

APOL06

APOL07

APOL08

APOL09

APOL10

EPC

APOL11

APOL12

:

APOL13

APOL14

APOL15



APLA01

APLA02

APLA03

APLA04

APLA05

()

APLA06

APLA07

APLA08

APLA09

APLA10

APLA11

APLA12



BPRO01

BPRO02

BPRO03

BPRO04

BPRO05

BPRO06



BHUM01

BHUM02

BHUM03

BHUM04

BHUM05

BHUM06

BHUM07

BHUM08

PMP

BHUM09

BHUM10

BHUM11

BHUM12

BHUM13



BFIN01

BFIN02

BFIN03

BFIN04

BFIN05



BINS01

BINS02



BKNO01

BKNO02

BKNO03

PMBOK,)

(ISO 10006 APM, BS6079, JPMF



CCOM01

CCOM02

CCOM03



CSTR01

CSTR02

CSTR03

CSTR04

CSTR05

MC

CSTR06



(DSS4)

CSYS01

CSYS02

EVMS

CSYS03

CSYS04

CSYS05

CSYS06

CSYS07

CSYS08

CSYS09

CSYS10



CCON01

CCON02

CCON03

CCON04

CCON05

CCON06

CCON07

CCON08

CCON09

CCON10

CCON11

CCON12

CCON13



DENV01



•

•

•

•

•

•

•

..

:

..

:

..

:

..

:

..

:

..

:

..

:

..

:

..

:

..

:

()

:()

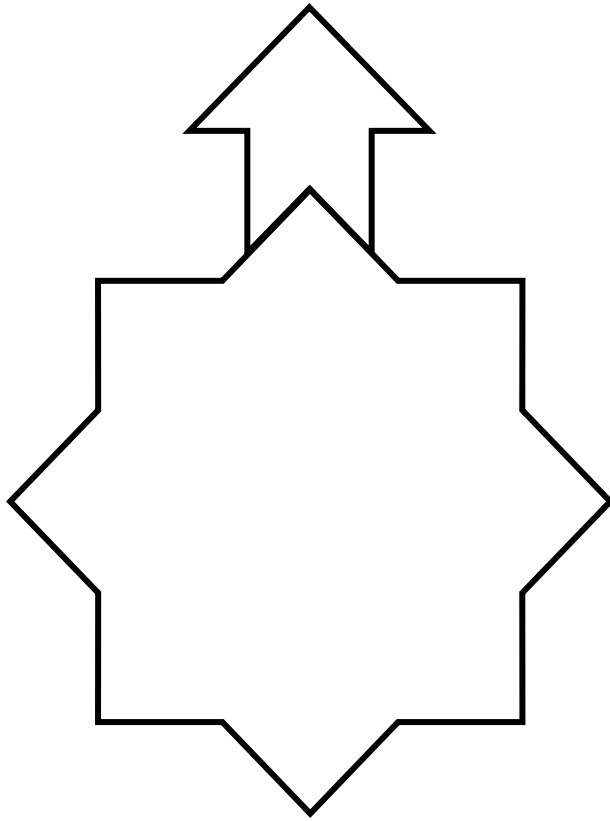

IT

.

.

.

..

:

.

..

: